

REINFORCED BACK MOORING BITT - Ø 100 MM

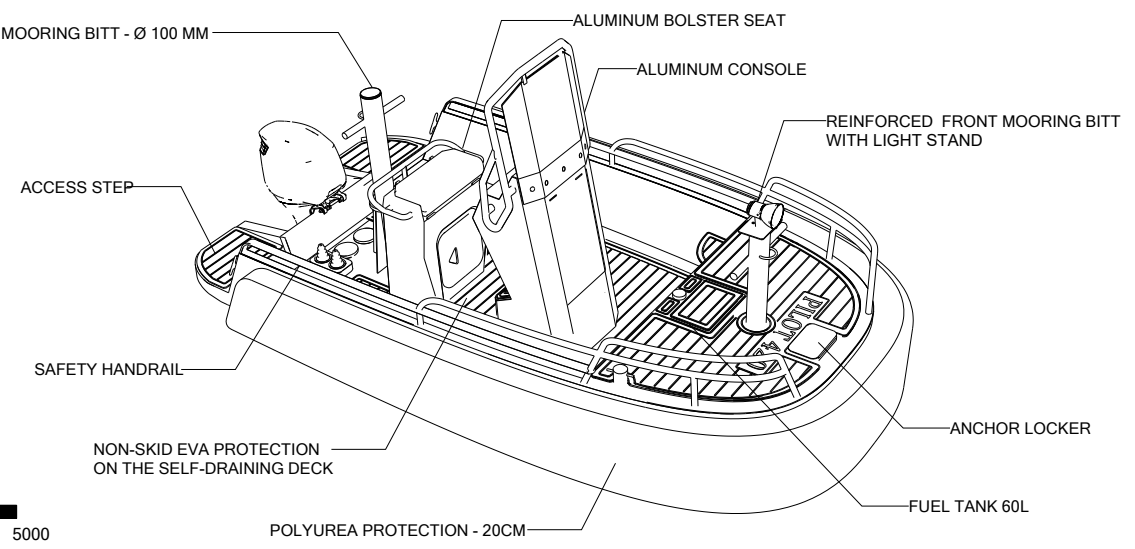

GENERAL ARRANGEMENT

PILOT 420



MAIN FEATURE PILOT 420	
LENGTH OVERALL	4.20 m
INTERIOR LENGTH	4 m
MAX WIDTH	2.30 m
INTERIOR WIDTH	1.70 m
DEPTH	0.86 m
PROTECTION THICKNESS	20 cm
NUMBER OF AIRTIGHT CHAMBERS	FULL POLYUREA
NAVIGATION CATEGORY	5th
DESIGN CATEGORY	D
HULL WEIGHT	341 kg
MAX LOAD	500 kg
MAX NUMBER OF PASSENGERS	4
MAX MOTORIZATION	50 HP
Shaft	Simple L
FUEL TANK	60 L

OUTBOARD ENGINE SPECIFICATIONS		
MAX POWER	HP	KW
	50	38
MAX WEIGHT	KG	LB
	114	251
SHAFT	50 HP	
	INCLUDED	CAPACITY
FUEL TANK	60 L	

X04	
KG	LB
1174	2588

FULL POLYUREA	
KG	LB
341	752

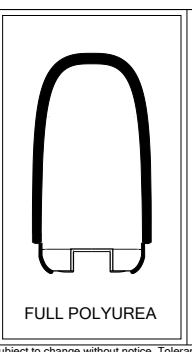

ALUMINUM HULL
POLYUREA PROTECTION
FRENCH DIVISION 222 BUREAU VERITAS NR600 STRUCTURE CERTIFICATION
CE
For more info : www.3dtender.com